

BERLIN 30

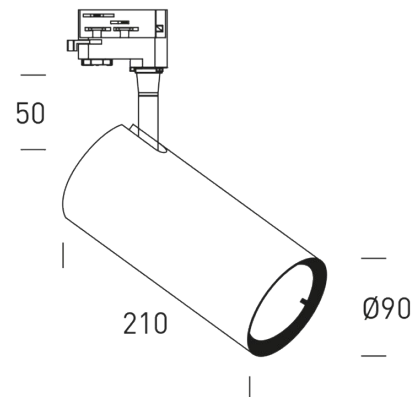

ESPECIFICACIONES

Versión	BERLIN 30
Tensión de alimentación	220-240V
Control	ON-OFF
Tipo de LED	LED SMD
Power (W)	21, 30
Real lumen	1730-1955-1860,2230-2625-2440
Temperatura de color	2K7-3K2-4K
CRI	CRI >80
UGR	UGR<19
Ángulo de emisión	45°
Color	Blanco
Medidas (mm)	90x210
Peso (Kg)	0.85
Material	Poliamida
Reflector	Aluminio
IP	IP20
Rango de temperatura	-20°C +40°C
Garantía	3 años



ACCESORIOS



Reflector 60°
Ref. 1.5027.8001

DETAILS DESCRIPTION



Switch de temperatura y de potencia ajustables



2 reflectores alu. disponibles (45° y 60°)